

# HEAVY DUTY FLOODED BATTERY

71035 (12V210Ah)



## CHARACTERISTICS

| Item                           | Specifications    |                      |
|--------------------------------|-------------------|----------------------|
| Nominal Voltage                | 12V               |                      |
| Nominal Capacity (20HR)        | 210Ah             |                      |
| Reserve Capacity               | 432min            |                      |
| Cold Cranking Amps@0°F (-18°C) | 1150A             |                      |
| Dimension                      | Length            | 518mm (20.4inches)   |
|                                | Width             | 274mm (10.8inches)   |
|                                | Height            | 236.5mm (9.31inches) |
| Approx Weight                  | 54.6g (120.4lbs)  |                      |
| Terminal                       | 1                 |                      |
| Cell layout                    | 3                 |                      |
| Hold-Down                      | B0                |                      |
| Case                           | Black-PP Material |                      |
| Cover                          | Black-PP Material |                      |
| Handle                         | TS8               |                      |

## APPLICATIONS

- Car start
- EV/HEV
- Engine start

## GENERAL FEATURES

- High capacity and high CCA
- Maintenance-free
- High vibration resistance
- Strong lead-calcium alloy grids for great corrosion resistance
- High strength PP case and cover no need be worried about breakage
- OE quality certification

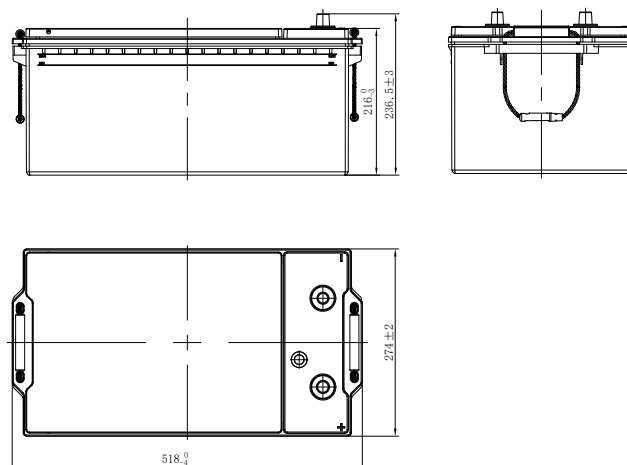
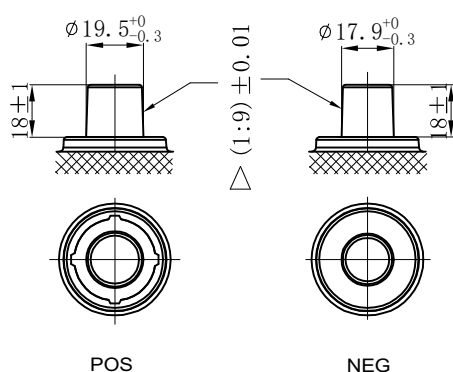

\*Values are subject to variation of +/- 5% in normal manufacturing processes.

Leoch International Technology Ltd.  
 www.leoch.com

Leoch Batteries Pte Ltd  
 www.leoch.sg

Leoch Battery Corporation  
 www.leochamericas.com

Leoch Europe S.A.  
 www.leoch.eu